

2 X UNITS of G5-2010.

Model: 144161

MU

5 ÷ 44 kW

Manual
Issue
Replaces

201330A02
02.99
09.96

**Use, installation
and instruction
manual**

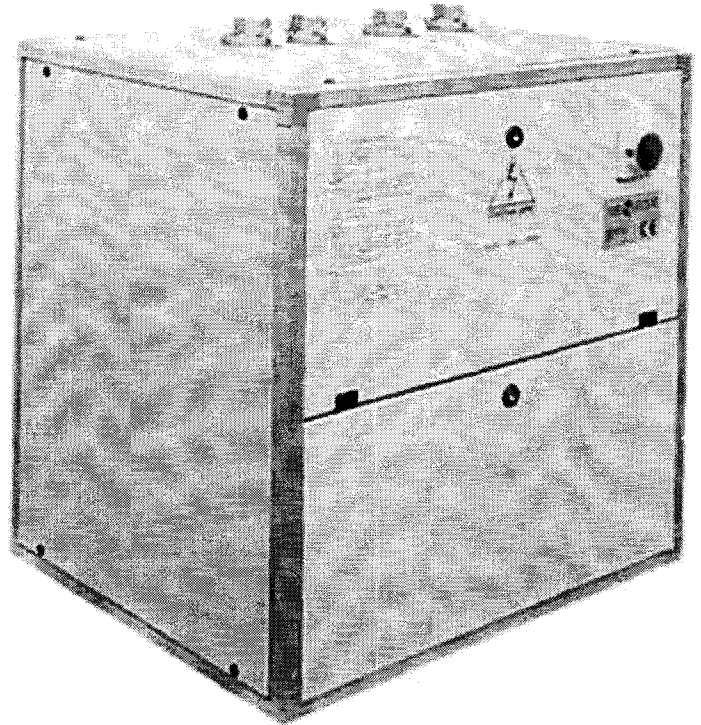

CE

R22
R407C

Water chillers

Water/water
packaged

Hermetic scroll
compressors

11
TAO
rest of the
G5-2010
units w/o



1.536/s dushad 19.1 kpa

TECHNICAL DATA MU SERIES

MODEL	21	31	36	41	61	81	91	101	141	161
Cooling capacity	5.3	8.2	9.7	11.8	14.4	17.3	22.5	30.2	37.2	44.4
Heating capacity	6.9	10.5	12.4	15.1	18.4	22.3	28.9	38.6	47.8	56.6
Compressor type	scroll hermetic	scroll hermetic	scroll hermetic	scroll hermetic	scroll hermetic	scroll hermetic	scroll hermetic	scroll hermetic	scroll hermetic	scroll hermetic
Oil charge	1	1.1	1.1	1.85	1.55	1.65	2.5	4.0	4.0	4.0
Evaporator type	plate	plate	plate	plate	plate	plate	plate	plate	plate	plate
Water volume	0.50	0.85	0.85	1.04	1.41	1.41	1.88	2.64	2.91	3.57
Max operat. pressure (refr. side)	30	30	30	30	30	30	30	30	30	30
Max operat. press. (water side)	10	10	10	10	10	10	10	10	10	10
Condenser type	plate	plate	plate	plate	plate	plate	plate	plate	plate	plate
Water volume	0.25	0.25	0.25	0.50	0.50	0.50	1.04	1.04	1.04	1.04
Max operat. pressure (refr. side)	30	30	30	30	30	30	30	30	30	30
Max operat. press. (water side)	10	10	10	10	10	10	10	10	10	10
Condenser type *	plate	plate	plate	plate	plate	plate	plate	plate	plate	plate
Water volume	0.50	0.85	0.85	1.04	1.41	1.41	1.88	2.64	2.91	3.57
Max operat. pressure (refr. side)	30	30	30	30	30	30	30	30	30	30
Max operat. press. (water side)	10	10	10	10	10	10	10	10	10	10
Storage tank	100	100	100	100	100	100	100	100	100	100
Setting safety valve	3	3	3	3	3	3	3	3	3	3
Expansion vessel	2	2	2	2	2	2	2	2	2	2
Pump nominal power	1 x 0.22	1 x 0.22	1 x 0.22	1 x 0.46	1 x 0.46	1 x 0.46	1 x 0.62	1 x 0.62	1 x 0.82	1 x 0.82
Flow rate	930	1410	1630	2010	2480	2980	3700	5130	6400	7690
Available pressure	60	60	60	120	100	80	100	80	110	80

* Fitted only in HP units or in units with condenser for tower water.

COOLING: condenser water temp. in 15 °C; evaporator water temp. in/out 12-7 °C.
 HEATING: evaporator water temp. in/out 15-10 °C; condenser water temp. in/out 40-45 °C.

TECHNICAL DATA MU LC SERIES

	21	31	36	41	61	81	91	101	141	161
MODEL										
Cooling capacity	5.0	7.7	8.8	10.9	13.4	16.1	19.9	27.6	34.5	41.7
Heating capacity	5.7	8.6	9.8	12.2	15.1	18.1	22.5	31.1	38.8	47.5
Compressor type	1	1.1	1.1	1.85	1.55	1.65	2.5	4.0	4.0	4.0
Oil charge	plate	plate	plate	plate	plate	plate	plate	plate	plate	plate
Evaporator type	0.50	0.85	0.85	1.04	1.41	1.41	1.88	2.64	2.91	3.57
Water volume	30	30	30	30	30	30	30	30	30	30
Max operat. pressure (refr. side)	10	10	10	10	10	10	10	10	10	10
Max operat. press. (water side)	100	100	100	100	100	100	100	100	100	100
Storage tank	3	3	3	3	3	3	3	3	3	3
Setting safety valve	2	2	2	2	2	2	2	2	2	2
Expansion vessel	1 x 0.22	1 x 0.22	1 x 0.22	1 x 0.46	1 x 0.46	1 x 0.46	1 x 0.62	1 x 0.62	1 x 0.82	1 x 0.82
Pump nominal power	930	1410	1630	2010	2480	2980	3700	5130	6400	7690
Flow rate	60	60	60	120	100	80	100	80	110	80
Available pressure										
	scroll hermetic	scroll hermetic	scroll hermetic	scroll hermetic	scroll hermetic	scroll hermetic	scroll hermetic	scroll hermetic	scroll hermetic	scroll hermetic

COOLING: evaporator water in/out 12-7 °C; condensing temperature 47 °C.

HEATING: evaporating temperature -2 °C; condenser water in/out 40-45 °C.

ELECTRICAL DATA MU SERIES

MODEL	21	31	36	41	61	81	91	101	141	161
Maximum absorbed power ⁽¹⁾	2.0 (2.2)	3.0 (3.2)	3.5 (3.7)	4.1 (4.5)	5.2 (5.6)	6.2 (6.6)	7.6 (8.2)	10.7 (11.3)	13.2 (14.0)	15.4 (16.2)
Maximum absorbed current ⁽²⁾	13.0 (13.9)	19.6 (20.5)	9.2 (10.1)	10.8 (13.0)	12.8 (15.0)	14.4 (16.6)	23.0 (25.9)	24.8 (27.7)	34 (35.6)	35.6 (37.2)
Maximum starting current	45.0 (45.9)	76.0 (76.9)	43.5 (44.3)	47.0 (49.2)	60.0 (62.2)	70.5 (72.7)	90.5 (93.4)	127.0 (129.9)	159.0 (160.6)	189 (190.6)
Main switch (QS)	32	32	32	32	32	32	32	32	32	80
Compr. nominal. absorb. power*	1.2	1.9	2.2	2.7	3.2	4.0	5.1	6.7	8.4	9.8
Compr. nominal. absorb. current*	5.9	8.8	4.2	5.6	6.8	7.2	10.7	12.9	15.2	17.9
Compr. nominal. absorb. power**	1.6	2.3	2.7	3.3	4.0	4.9	6.2	8.3	10.3	12.1
Compr. nominal. absorb. current**	7.3	10.9	5.0	6.2	7.8	8.5	11.9	14.7	17.5	20.8
Compressor circuit breaker (QMC)	25	25	16	16	16	25	32	32	40	40
Auxiliary circuit breaker (QFA)	6	6	6	6	6	6	6	6	6	6
Pump motor protection (QMP)	---	---	---	---	---	---	---	---	---	---
Pump motor nomin. abs. power	1 x 0.22	1 x 0.22	1 x 0.22	1 x 0.46	1 x 0.46	1 x 0.46	1 x 0.62	1 x 0.62	1 x 0.82	1 x 2.5
Pump motor nomin. abs. current	1 x 0.92	1 x 0.92	1 x 0.92	1 x 2.2	1 x 2.2	1 x 2.2	1 x 2.9	1 x 2.9	1 x 1.6	1 x 1.6
Electric supply	230/1/50									
Electric supply auxiliary	230-24/1/50 400/3+N/50									

(1) Referred to maximum declared operating conditions

* COOLING: condenser water temp. in 15 °C ; evaporator water temp. in/out 12-7 °C.

** HEATING: evaporator water temp. in/out 15-10 °C ; condenser water temp. in/out 40-45 °C.

(2) Referred to cut-off compressor internal protection
Values enclosed in brackets are referred to PF, ST version units

ELECTRICAL DATA MU LC SERIES

MODEL	21	31	36	41	61	81	91	101	141	161
Maximum absorbed power ⁽¹⁾	2.0 (2.2)	3.0 (3.2)	3.5 (3.7)	4.1 (4.5)	5.2 (5.6)	6.2 (6.6)	7.6 (8.2)	10.7 (11.3)	13.2 (14.0)	15.4 (16.2)
Maximum absorbed current ⁽²⁾	13.5 (14.4)	19.0 (20.0)	8.0 (9.0)	10.5 (12.7)	12.5 (14.7)	14.0 (16.2)	18.2 (21.1)	24.8 (27.7)	30.1 (31.7)	35.6 (37.2)
Maximum starting current	45.0 (45.9)	76.0 (76.9)	43.5 (44.3)	47.0 (49.2)	60.0 (62.2)	70.5 (72.7)	90.5 (93.4)	127.0 (129.9)	159.0 (160.6)	189.0 (190.6)
Main switch (QS)	32	32	32	32	32	32	32	32	80	80
Compr. nominal. absorb. power*	1.5	2.3	2.4	3.1	3.8	4.5	6	7.6	9.5	11.5
Compr. nominal. absorb. current*	7.0	10.2	4.4	6.0	7.4	8.0	11.4	11.6	16.7	9.8
Compr. nominal. absorb. power**	1.6	2.3	2.8	3.2	4.0	4.8	6.1	8.2	10.3	12.1
Compr. nominal. absorb. current**	7.3	11.0	5	6.1	7.6	8.5	11.8	12.6	17.4	20.6
Compressor circuit breaker (QMC)	25	25	16	16	16	25	32	32	40	40
Auxiliary circuit breaker (QFA)	6	6	6	6	6	6	6	6	6	6
Pump motor protection (QMP)	---	---	---	---	---	---	---	---	1.6-2.5	1.6-2.5
Pump motor nomin. abs. power	1 x 0.22	1 x 0.22	1 x 0.22	1 x 0.46	1 x 0.46	1 x 0.46	1 x 0.62	1 x 0.62	1 x 0.82	1 x 0.82
Pump motor nomin. abs. current	1 x 0.92	1 x 0.92	1 x 0.92	1 x 2.2	1 x 2.2	1 x 2.2	1 x 2.9	1 x 2.9	1 x 1.6	1 x 1.6
Electric supply	230/1/50						400/3+N/50			
Electric supply auxiliary					230-24/1/50					

(1) Referred to maximum declared operating conditions
 * COOLING: evaporator water in/out 12-7 °C; condensing temperature 47 °C.
 ** HEATING: evaporating temperature -2 °C; condenser water in/out 40-45 °C.
 (2) Referred to cut-off compressor internal protection
 Values enclosed in brackets are referred to PF, ST version units

CONTENTS

Section	Topic	Page
	MU SERIES	1
	FIELD OF APPLICATION	1
1.	GENERAL INFORMATION	1
2.	INSPECTION, HANDLING, POSITIONING	1
2.1.	Inspection	1
2.2.	Lifting and handling	1
2.3.	Unpacking	2
2.4.	Positioning	2
3.	INSTALLATION	3
3.1.	Installation clearances	3
3.2.	General recommendations for hydraulic connections	3
3.3.	Evaporator hydraulic connections (user exchanger)	6
3.4.	Condenser hydraulic connections (source exchanger)	7
3.4.1.	<i>Coolant connections to remote air heat exchanger (LC versions)</i>	7
3.5.	Hydraulic connections to the desuperheater/regenerative condenser (optional)	7
3.6.	Operating limits	8
3.6.1.	<i>Water flow to the user exchanger</i>	8
3.6.2.	<i>Chilled water temperatures (summer cycle)</i>	8
3.6.3.	<i>Hot water temperature (winter cycle)</i>	8
3.7.	Water quality	9
3.8.	Low water temperature operation	9
3.9.	Electrical connections	9
3.9.1.	<i>General</i>	9
3.9.2.	<i>Circulation pump electrical connections</i>	10
3.9.3.	<i>Remote control</i>	10
3.9.4.	<i>Phase sequence relay</i>	10
3.9.5.	<i>Water solenoid valve (heat pump versions only)</i>	11
3.9.6.	<i>Electrical panel layout</i>	11
4.	START-UP	15
4.1.	Preliminary checks	15
4.2.	Putting the unit into service	15
4.3.	Checks during unit operation	16
4.4.	Coolant charge check	16
4.5.	System shutdown	17
4.6.	Defrosting (MU/LC/HP units only)	17
4.7.	Refrigerant circuit diagrams	18
5.	CONTROL AND SAFETY DEVICE CALIBRATION	23
5.1.	General	23
5.2.	Maximum pressure switch	23
5.3.	Minimum pressure switch	23
5.4.	Service thermostat	24
5.5.	Antifrost thermostat	24
5.6.	Flow switch	24
5.7.	Anti-recycle timer	24

5.8. Defrosting thermostat (LC heat pumps only)	24
5.9. End defrosting pressure switch (LC heat pumps only)	25
6. MAINTENANCE AND PERIODIC CHECKS	26
6.0. Warnings	26
6.1. General	26
6.2. Refrigerant circuit repairs	26
6.2.1. <i>Tightness test</i>	26
6.2.2. <i>High vacuum and drying of the refrigerant circuit</i>	27
6.2.3. <i>Coolant charge</i>	27
6.2.4. <i>Environmental considerations</i>	27
7. TAKING THE UNIT OUT OF SERVICE	27
8. TROUBLESHOOTING	28
10. DIMENSIONS AND WEIGHTS	36

MU SERIES

The MU series of chillers and heat pumps with plate-type exchanger and power ratings between 5 and 45 kW (from 4300 frig/h to 38700 frig/h) comes in the following versions:

- **MU** water chiller with scroll compressor
- **MU/HP** heat pump with scroll compressor
- **MU/ST** water chiller with storage tanks, pump and scroll compressor
- **MU/ST/HP** heat pump with storage tank, pump and scroll compressor
- **MU/PF** water chiller with water circulation pump and scroll compressor
- **MU/PF/HP** heat pump with water circulation pump and scroll compressor
- **MU/LC** evaporator unit with scroll compressor, prearranged for remote air condenser
- **MU/LC/HP** heat pump with scroll compressor, prearranged for remote air heat exchanger
- **MU/ST/LC** evaporator unit with tank, pump, scroll compressor, prearranged for remote air condenser
- **MU/ST/LC/HP** heat pump with tank, pump, scroll compressor, prearranged for remote air heat exchanger
- **MU/PF/LC** evaporator unit with water circulation pump, scroll compressor, prearranged for remote air condenser
- **MU/PF/LC/HP** heat pump with water circulation pump, scroll compressor, prearranged for remote air heat exchanger

FIELD OF APPLICATION

These units are designed for the cooling (cooling-only version) or the cooling/heating (heat pump version) of water, generally used in air conditioning and chilling applications.

The recommended operating limits of all units are given in paragraph 3.6 of this manual.

1. GENERAL INFORMATION

- Always comply with the safety instructions given in this manual, the indications given on the unit and all required precautions when installing or performing operations on the cooling assembly;
- Cooling circuit pressure and electrical components can be sources of risk during machine installation or maintenance; for this reason, such operations should be carried out by qualified personnel only;
- Failure to comply with the instructions given in this manual or unauthorised modifications to the unit will automatically render the guarantee null and void.

CAUTION Always disconnect electricity supply before performing operations on the unit.

2. INSPECTION, HANDLING, POSITIONING

2.1. Inspection

The machine has left the factory in perfect condition.

When the unit is received, carry out a thorough inspection to verify that it has not been damaged in any way during shipping. Any damage must be reported immediately to the shipping agent and recorded on the Delivery Sheet before the latter can be countersigned. Report the nature and extent of damage to your dealer promptly.

The Customer is responsible for making a full written report on any significant damage found on the unit.

2.2. Lifting and handling

Be careful to prevent jolting or sudden movements during unit unloading and positioning. Handle the unit carefully during in-house transportation. Never use machine components for lifting or moving. Units can be transported by means of a lift truck; insert the lift forks under the pallet (see figure).

CAUTION: before all lifting operations, secure the unit properly to prevent it from tipping or falling.

2.3. Unpacking

Remove the packing from the unit carefully to avoid damage. The different types of packing material (wood, cardboard, nylon etc.) should be separated and handed over to authorised agencies for disposal or recycling.

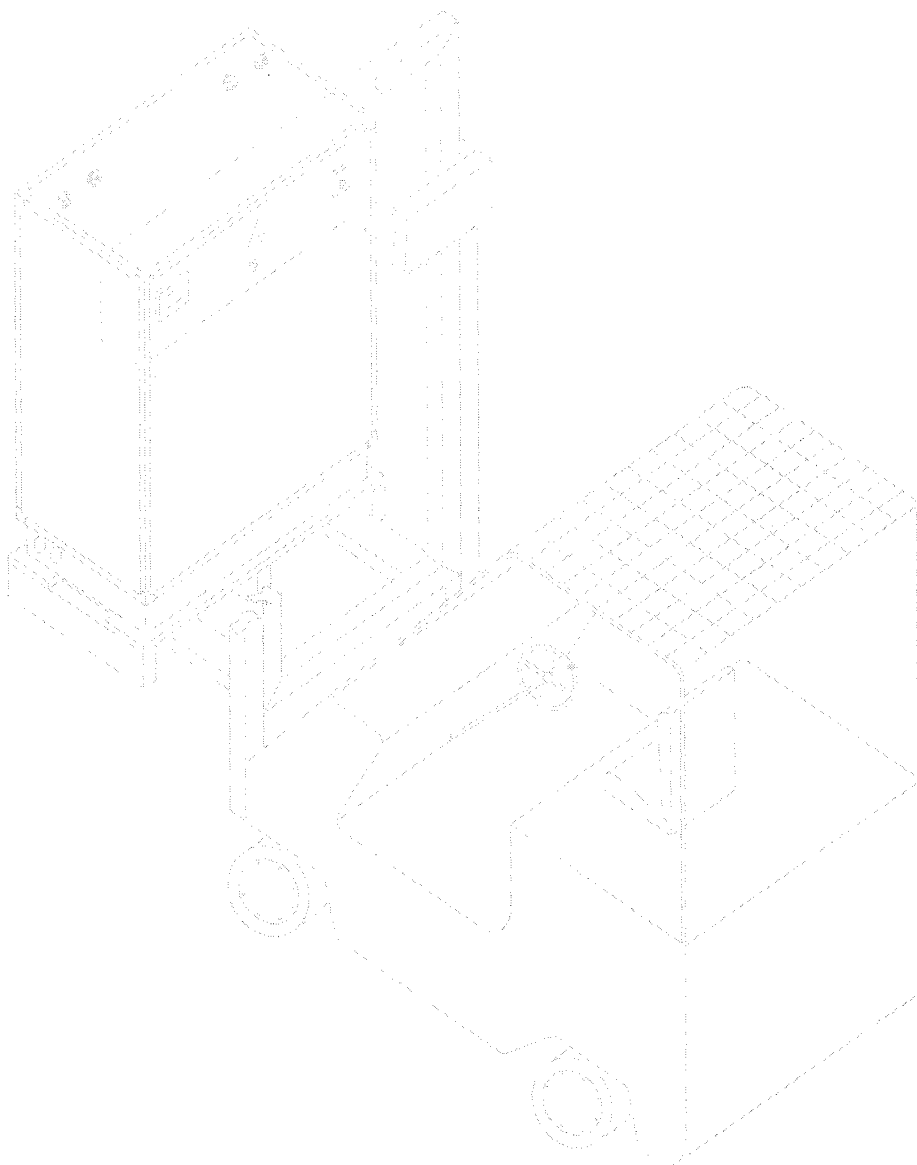

2.4. Positioning

Units must be positioned in a covered area, with a minimum ambient temperature of 4°C.

These machines cause only a limited amount of vibration. It is however a good idea to place a rigid rubber strip between the base and the support surface (floor or concrete bed).

Should vibration damping supports be required, contact the engineering department of the manufacturer.

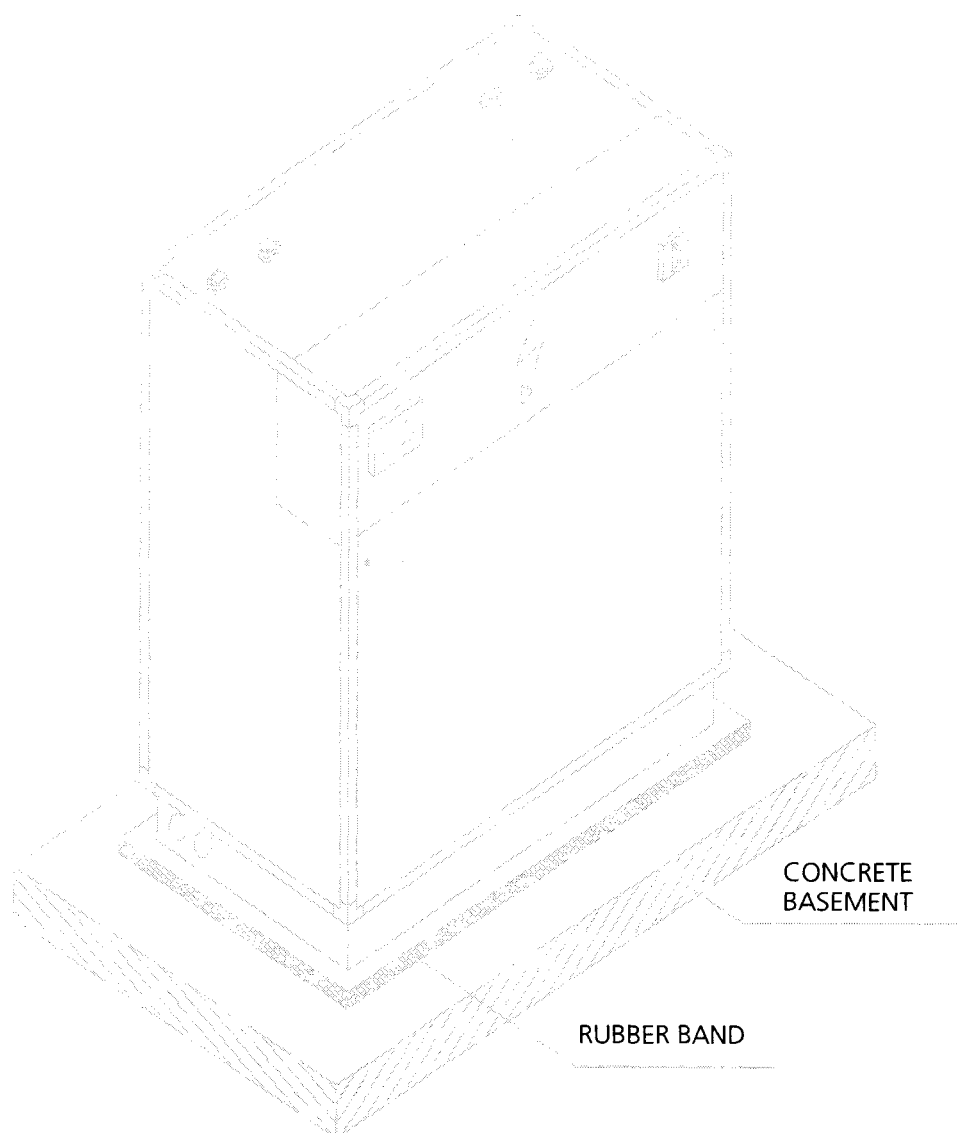

3. INSTALLATION

3.1. Installation clearances

Total accessibility to service areas around the unit, as shown in the dimensional diagrams, must be assured.

MU series units have been designed and built for indoor installation only.

3.2. General recommendations for hydraulic connections

When setting up the hydraulic system on the evaporator, observe the following instructions and relevant national or local regulations. Refer to the diagrams included in this manual.

RECOMMENDED HYDRAULIC CIRCUIT FOR 21-161 MU/MU HP SERIES UNITS

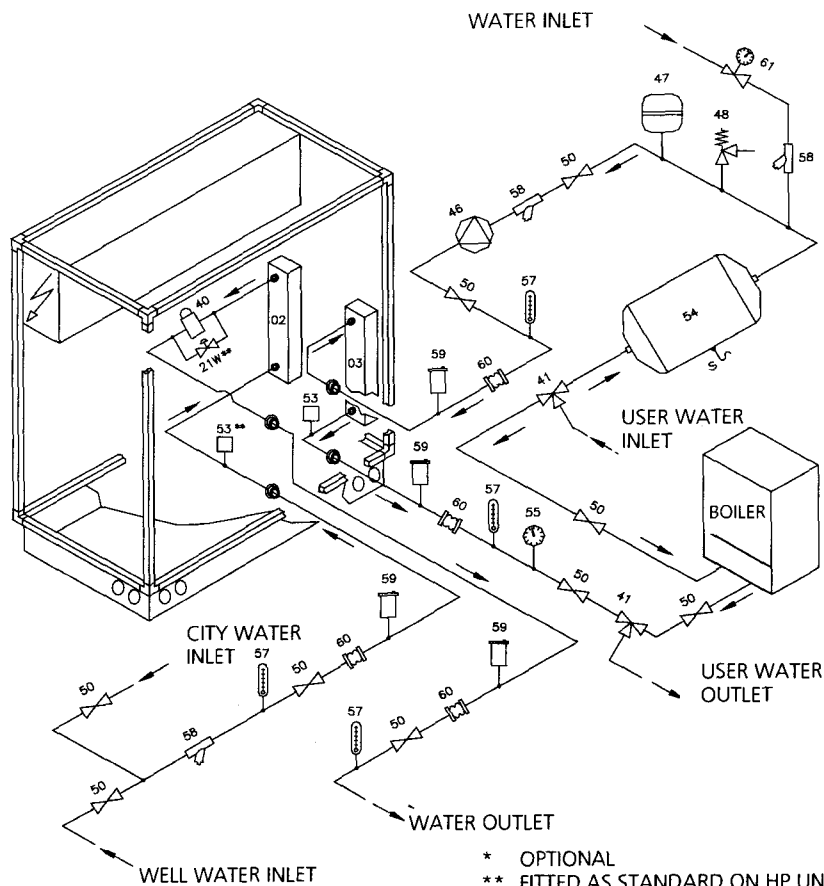

* OPTIONAL
 ** FITTED AS STANDARD ON HP UNITS

53	FLOW SWITCH
50	GATE VALVE
48	SAFETY VALVE
47	EXPANSION VESSEL
46	WATER PUMP
41	3-WAY VALVE
40	PRESSOSTATIC VALVE
21W	SOLENOID VALVE ON SIDE LOSS WATER
17	ELECTRIC HEATER
03	EVAPORATOR
02	CONDENSER
POS.	DESIGNATION

S	TANK DRAIN PLUG
61	CIRCUIT FILLING GROUP
60	FLEXIBLE CONNECTORS
59	VENT VALVE
58	FILTER
57	THERMOMETER
55	WATER GAUGE
54	STORAGE TANK
POS.	DESIGNATION

RECOMMENDED HYDRAULIC CIRCUIT FOR 21-161 MU ST/MU ST HP SERIES UNITS

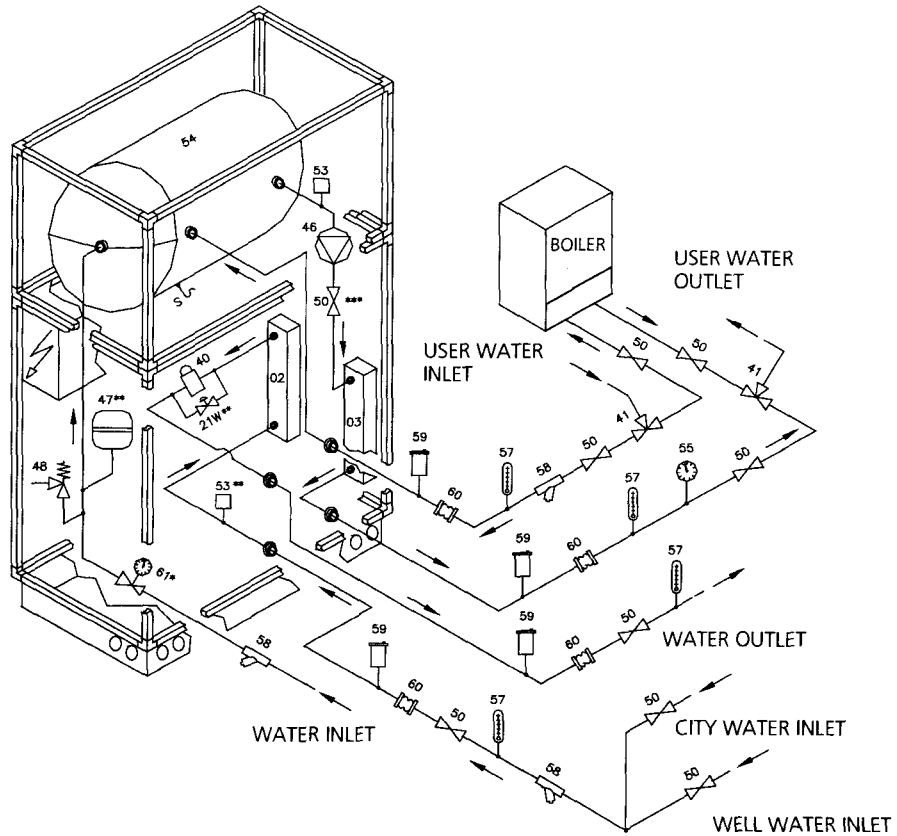

- * OPTIONAL
- ** FITTED AS STANDARD ON HP UNITS
- *** NOT AVAILABLE WITH MODELS 21-36; STANDARD WITH ALL OTHER MODELS

54	STORAGE TANK
53	FLOW SWITCH
50	GATE VALVE
48	SAFETY VALVE
47	EXPANSION VESSEL
46	WATER PUMP
41	3-WAY VALVE
40	PRESSOSTATIC VALVE
21W	SOLENOID VALVE ON SIDE LOSS WATER
03	EVAPORATOR
02	CONDENSER
POS.	DESIGNATION

S	TANK DRAIN PLUG
61	CIRCUIT FILLING GROUP
60	FLEXIBLE CONNECTORS
59	VENT VALVE
58	FILTER
57	THERMOMETER
55	WATER GAUGE
POS.	DESIGNATION

- Use flexible joints to connect the pipes to the chiller in order to prevent the transmission of vibrations and to compensate for heat dilation.
- Fit the following components to the pipes:
 - stop valves, temperature and pressure indicators for routine maintenance and control of the assembly;
 - water traps on inlet and outlet pipes for temperature readings (if temperature indicators have not been fitted);
 - gate valves to isolate the unit from the water circuit;
 - metal filter with 1 mm max. mesh to the inlet pipes to protect the exchanger from impurities in the water supply;
 - vent valves in the upper section of the water circuit to bleed incondensable products;
 - expansion vessel and automatic load valves (optional on ST versions) to maintain system pressure and compensate for heat dilation;
 - discharge valve and drain tank (as necessary) for unit drainage during maintenance or seasonal disuse.

Install a safety valve (supplied as standard accessory on ST units on user side). A safety valve will discharge the circuit in the event of emergency situations (e.g. fire) to prevent explosions. Connect the discharge to a tube with a diameter no smaller than that of the valve, and direct discharge flow to a safe area.

Caution: Keep naked flames well clear of the unit when making hydraulic connections.

3.3. Evaporator hydraulic connections (user exchanger)

Make sure that inlet water is connected to the fitting marked "INGRESSO ACQUA UTENZE". Incorrect connection of inlet water could lead to the risk of evaporator freezing, given that thermostat control would be neutralised, as well as the risk of overloading, since the operating thermostat is pre-calibrated to inlet water conditions.

Hydraulic fittings include brass threaded joints (for dimensions and positions, see the dimensional diagrams).

The water circuit must be configured to guarantee constant water flow to the evaporator, in all operating conditions. Discontinuous water flow could lead to the risk of liquid coolant returning to the compressor inlet, which could damage the compressor.

Compressor operation is intermittent, given that cooling requirements do not coincide with compressor output. In the case of systems with low water content (in which the thermal inertia of water is less significant), make sure that the water content satisfies the following relation:

$$V = P/(46.5) \leftrightarrow P/(34.9)$$

where:

V= water volume [litres]

P= unit power yield [Watt]

If the above volumes are not met, a storage tank should be fitted.

This type of tank does not require any particular attention, however **it must be completely insulated (as all chilled water pipes) to prevent condensation and reduction of system efficiency.**

These units are fitted with plate-type exchangers; for this reason, the installation of a 1 mm (max.) mesh metal filter on the inlet water line is highly recommended.

Safety flow switches are fitted as standard on all MU series units.

3.4. Condenser hydraulic connections (source exchanger)

Make sure that inlet water is connected to the fitting marked "CONDENSING WATER INLET".

Hydraulic fittings include brass threaded joints (for dimensions and positions, see the tables at the end of the manual).

The hydraulic circuit must assure a nominal flow that maintains a condensation temperature of approx. 40 °C during summer operation.

The MU series has been designed to mount a plate-type exchanger for use with mains water (inlet temperature 15 °C). Units are fitted with flow control (pressure) valve to limit water consumption.

An optional oversized condenser for use with an evaporating tower (or with closed DRY COOLER circuit) is also available; in this case a pressure control valve is not required.

These units are fitted with plate-type exchangers; for this reason, The installation of a metallic filter with a mesh smaller than 1 mm on water inlet connections is compulsory. If the metallic filter should not be present on the unit the warranty will terminate immediately.

Safety flow switches are fitted as standard on MU HP series units, and are therefore not required on heat pump versions.

3.4.1. Coolant connections to remote air heat exchanger (LC versions)

In the remote condenser version (or HP evaporators during winter operation), the two units can be connected by copper pipes that are adequately dimensioned to the required application. In normal conditions, this connection can be made over a distance up to 20 metres, with a height difference between the two units of 6 metres. For further information, contact the manufacturer's Engineering Department.

3.5. Hydraulic connections to the desuperheater/ regenerative condenser (optional)

In the case of units fitted with desuperheater or regenerative condenser, install a three-way modulating valve with temperature probe on the inlet water connection to the exchanger.

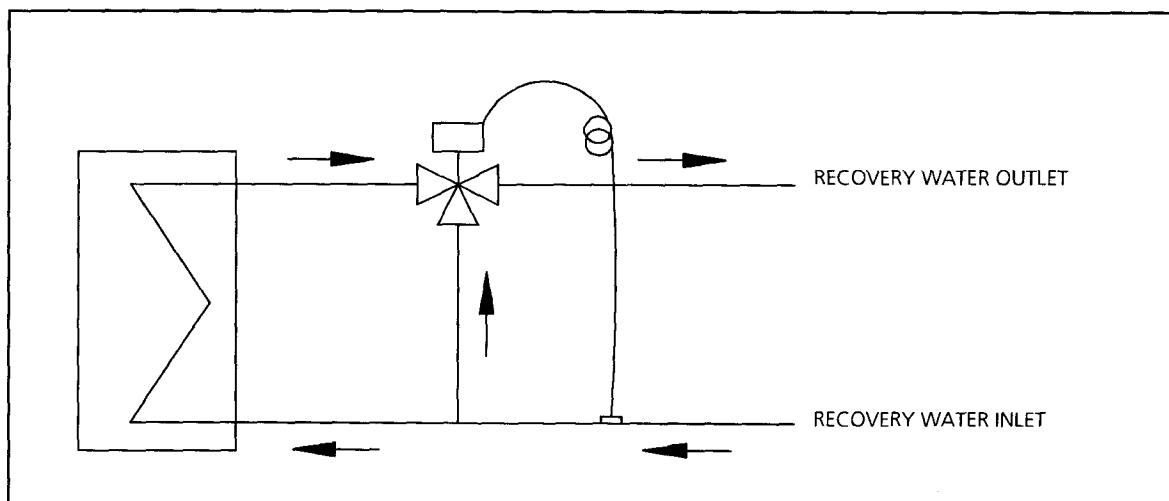

In this way, water flow will increase in proportion to the increase in water temperature, thereby ensuring optimal unit operation (see figure on next page).

3.6. Operating limits

3.4.1. Water flow to the user exchanger

The water flow supplied by the unit refers to a thermal head between inlet and outlet water of 5° C in relation to the available cooling power.
 The maximum permitted flow is that with a thermal head of 3.5 °C. Unacceptable load loss values with the risk of exchanger erosion are possible.
 The minimum permitted flow is that with a thermal head of 8 °C: lower flow values could lead to excessively low evaporation temperatures, causing assembly safety devices to cut in.

3.6.2. Chilled water temperatures (summer operation)

The minimum temperature at the evaporator outlet is 4 °C; for lower temperatures, refer to the information given in paragraph 3.8.
 The maximum temperature at the evaporator inlet is 20 °C. In the case of higher temperatures, the entire circuit will require appropriate modifications (twin circuits, three-way valves, by-pass valves, storage tanks).

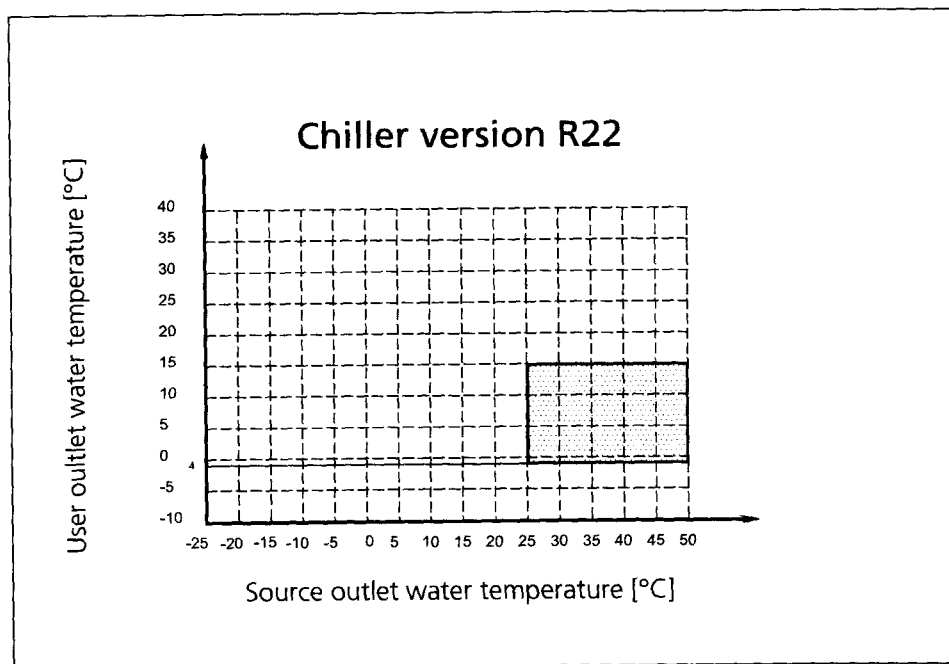

3.6.3. Hot water temperature (winter operation)

During normal system operation, the temperature of the inlet water to the condenser must not drop below 30 °C; lower temperatures could cause the compressor to malfunction or break down.
 The maximum temperature of condenser outlet water is 50 °C. Higher temperatures will cause the safety devices to shut down the assembly.

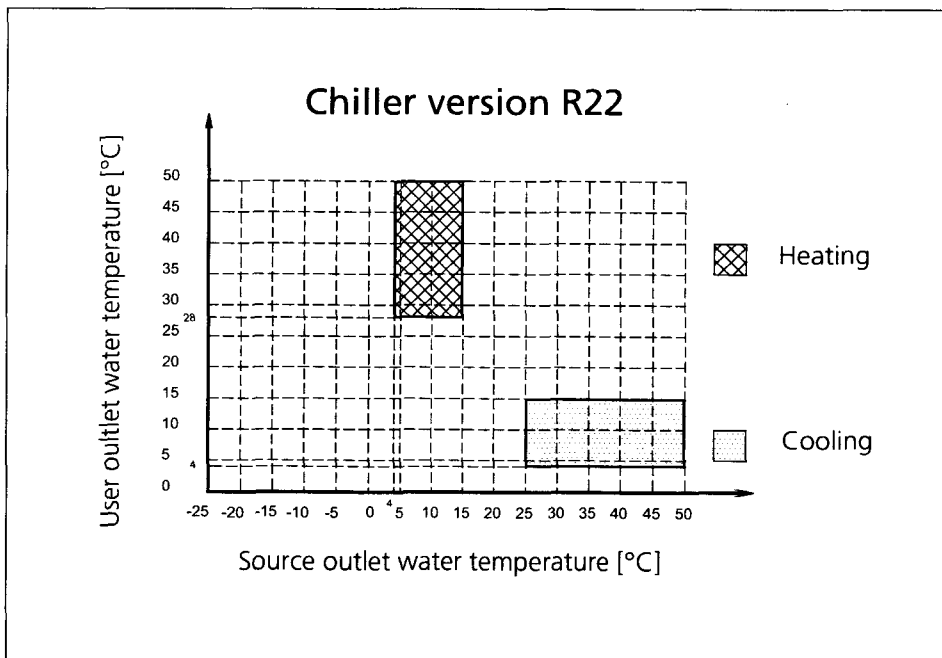

3.7. Water quality

If well or river water is used, corrosion or material build-up could become a problem. Check the water pH, electrical conductivity, presence of ammonia ions, sulphur and chlorine, hardness, etc., then apply the required chemical treatment.

3.8. Low water temperature operation

In the event that it is necessary to operate the unit for low water temperatures (< 4 °C at evaporator outlet), use a mixture of water and ethylene glycol. Adjust the calibration of the service and anti-frost thermostats accordingly:

- set the anti-frost thermostat to at least 3-5 °C above the mixture freezing point (this setting is normally made by the manufacturer).

The percentage of glycol (and therefore its weight) is determined by the temperature of chilled water required (see **Table II**).

TABLE II - WATER -ETHYLENE GLYCOL MIXTURE FREEZING POINT

Percentage in weight	%	10	20	30	40	50
Freezing point	°C	-4.8	-9.9	-17.2	-26.6	-38.3

3.9. Electrical connections

3.9.1. General

Make sure that the unit has been disconnected from the power supply before carrying out the following operations.

Check that mains power corresponds to unit specifications (voltage, number of phases, frequency) shown on the data plate.

Thread the cables through the fairleads on the machine upright and on the board.

Check that the cable section and line protections are those specified in the wiring diagram.

Ensure that mains voltage is not subject to variations greater than $\pm 5\%$ and that the imbalance between phases does not exceed 2%.
If these problems exist, consult the manufacturer's Engineering Department for the selection of appropriate protective devices.

Operation of the unit outside the recommended values given above will immediately render the guarantee null and void.

Make all electrical connections in compliance with the instructions given on the wiring diagram supplied with the unit.

An earth connection is required by law. The unit installation technician is responsible for connecting the earth wire to the earth bar in the electrical panel.

The control circuit power is derived from the power line by means of a transformer on the electrical panel. The control circuit is protected by a general automatic circuit-breaker; the board is protected by a 5x20T 2A fuse.

3.9.2. Circulation pump electrical connections

The circulation pump interlocking the chiller must remain connected to unit control in order to prevent its operation in the event of malfunction. **Connect the pump contacts in series to terminals N2-34.**

The pump must be started up approx. 60 seconds before the chiller, and shut down approx. 60 seconds after it.

3.9.3. Remote control

For remote ON-OFF control of the unit, connect the external permissive to the GND – ID5 contacts on the microprocessor.

This operation involves the modification of certain parameters stored in the controller. Contact the manufacturer's Engineering Department for correct reprogramming procedure.

CAUTION: the external permissive connection wires must be kept at a distance from power lines or shielded to prevent interference to the control microprocessor.

Refer to the wiring diagram when making the connections described in paragraphs 3.9.2 - 3.9.3. Connection wires must have a minimum section of 1.5 mm² as required by CEI 64-8 (IEC 364, HD384).

3.9.4. Phase sequence relay

To prevent breakage of the scroll compressor caused by incorrect turning of the rotor (indicated by loud noise), three-phase units (models 36-161) are fitted with an electronic phase sequence relay that prevents inverse compressor rotation by shutting down the microprocessor in the event that the power phase sequence is incorrect.

The start permissive given by the relay (on the electrical panel) is indicated by a green LED; alternatively, invert the connection of two phases on the terminal board.

3.9.5. Water solenoid valve (heat pump versions only)

Heat pump units are fitted with a solenoid valve that control the water flow to the exchanger during winter operation.

The pressure valve is not fitted on units featuring an oversized condenser (with an evaporating tower or closed dry cooler circuit). The units will be thus configured:

Unit	Condenser	Pressure valve	Solenoid valve
MU/MU ST/MU PF	Standard	YES	NO
MU/MU ST/MU PF	Oversized (Optional)	NO	NO
MU HP/MU STHP/ MU PF HP	Oversized	YES	YES

3.9.6. Electrical panel layout

MU 2.1-41 (2006-11-13)
ELECTRICAL

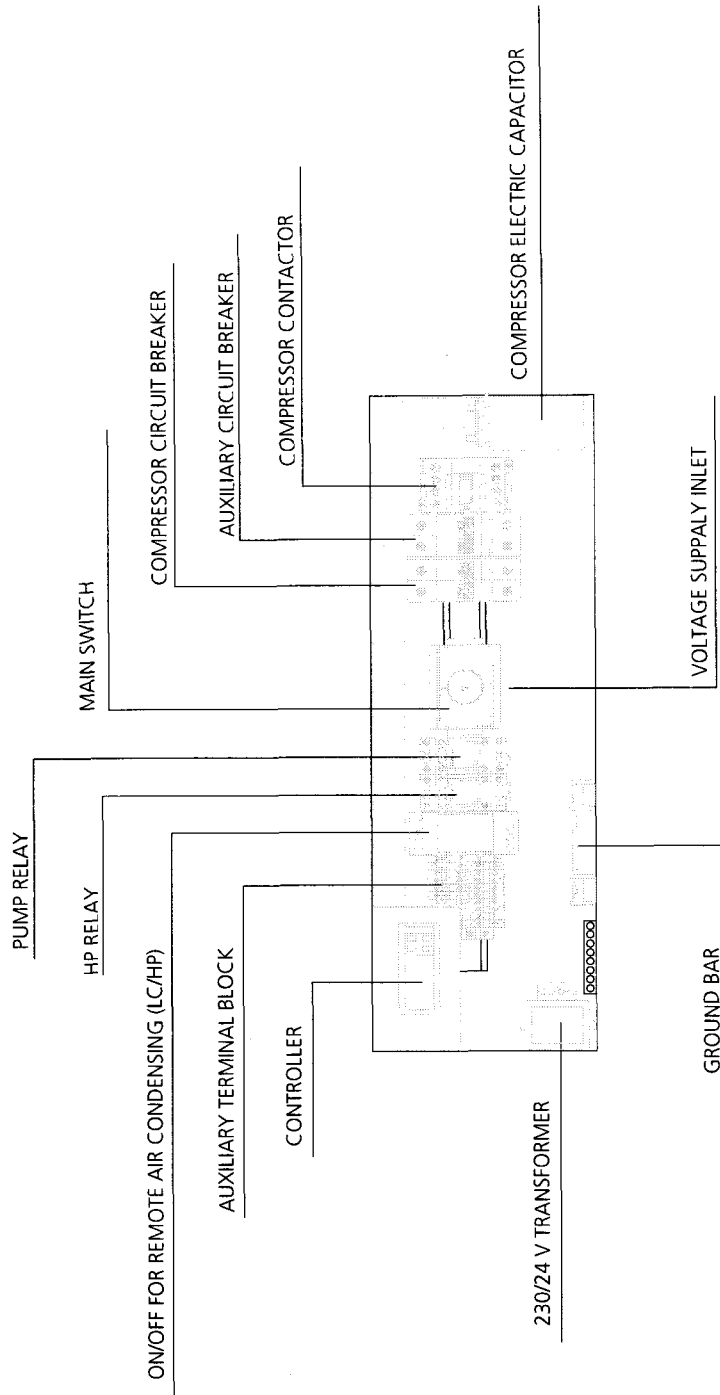

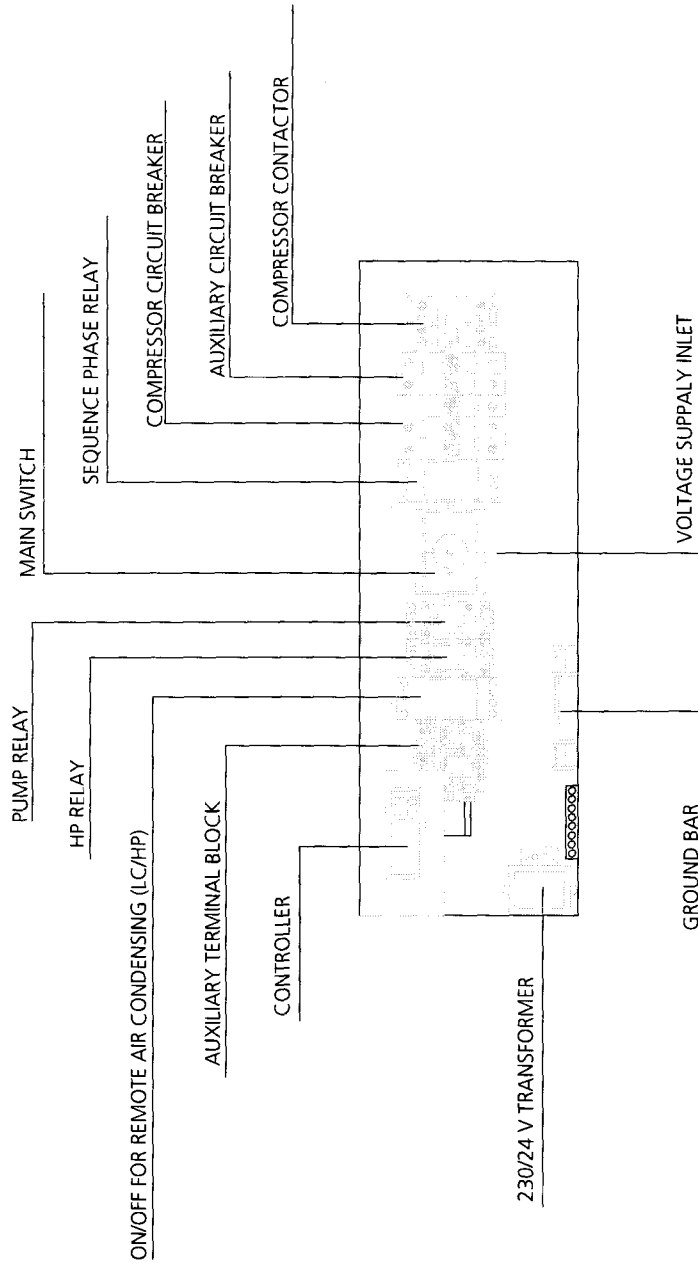

MU 21-81 400/50N/53
L.C. 10001 1000

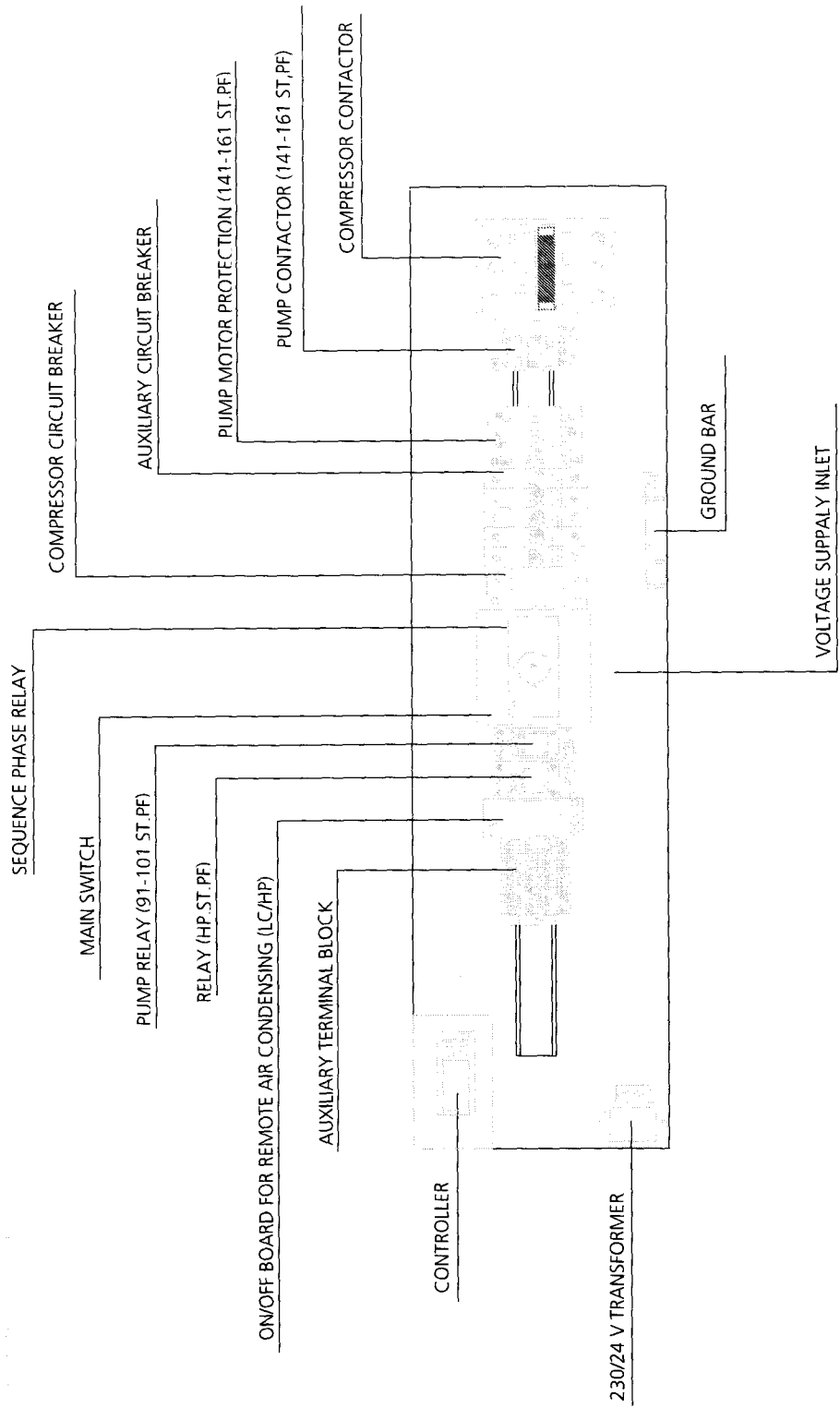

4. START-UP

4.1. Preliminary checks

- Check that the electrical connections have been made correctly, and that all terminals are firmly tightened.
- Use a tester to check that the voltage at the input terminals corresponds to that specified by the wiring diagram ($\pm 5\%$). If the voltage is subject to frequent variation, consult the manufacturer's Engineering Department for the selection of appropriate protection devices.
- Check for leakage of coolant fluid (use a leak finder as necessary).
- Check that the guard heaters are correctly powered. **The heaters must be inserted at least 12 hours before unit start-up; this happens automatically when the main switch is on.** Check the lower part of the compressors should be warm, at least 10 – 15 °C higher than ambient temperature.
- Check that the hydraulic connections have been made correctly in compliance with the specifications given on the machine data plate.
- Check that the hydraulic system has been bled of residual air; charge the system slowly and open the bleed valves at the top (fitted by the installation technician, as well as the expansion vessel; see section 3.2).

Caution: check that all unit panels are in place and secured before system start-up.

4.2. Putting the unit into service

Close the main switch, then proceed as follows:

- Select the required operation cycle (heating or cooling) by pressing the relative control button:

ON-OFF BUTTON (cooling)

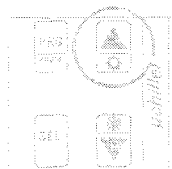

press the button for 5 seconds while the machine is on stand by to enable or disable the cooling mode; pressing the button will have no effect if the machine is operating in heat pump (heating) mode.

- * this LED will appear on the display at the same time to indicate that the machine is operating in cooling mode.

ON-OFF BUTTON (heating)

press the button for 5 seconds while the machine is on stand by to enable or disable the heat pump (heating) mode; pressing the button will have no effect if the machine is operating in cooling mode.

- * this LED will appear on the display at the same time to indicate that the machine is operating in heat pump (heating).

N.B. This operation is required for heat pump versions only.

Important: switch over the operating cycle at the end of season only. Frequent switching between heating and cooling modes can impair and damage the compressor.

- Check that the service thermostat is calibrated to the nominal values specified in table V; in this way, the assembly will start up when a permissive signal is received from the thermostat or the safety devices (flow switch, pressure switch, thermal cut-out switch, etc.), in accordance with time settings.

The service LEDs on the controller display indicate machine status.

If neither of these LEDs are on, the machine is on stand-by; the compressor LED indicates machine status when not in stand-by mode:

- ⊖ off: the compressor is not required by the setting
- flashing: the compressor is required by the setting, though is not operating due to cut in of time or safety devices
- on: the compressor is operating

Disconnect the unit from the power supply only before prolonged periods of disuse, e.g. seasonal shutdown. For temporary machine shutdown, follow the instructions given above.

4.3. Checks during unit operation

- After the compressors have been operating for a few minutes, check that condensing is around 40 °C in summer operation, or 55 °C in winter operation: to make this check, use pressure gauges or place a thermometer at the condenser outlet to check that the water temperature is around 35 °C (summer operation) or 50°C (winter operation) in normal conditions.
- Check that the temperature at the user exchanger inlet is close to the service thermostat setting.
- ST version units (with pump and storage tank): in the event of noisy pump operation (due to misalignment of system load loss with pump head), adjust the delivery valve until normal operation is resumed.

4.4. Coolant charge check

- After the unit has been operating for a few hours, check that the liquid indicator has a green crown. Yellow indicates the presence of humidity in the circuit, and must be rectified by a qualified technician.
- Check for bubbles in the liquid indicator. Frequent bubbles can be indicative of insufficient coolant in the circuit. Occasional bubbles are considered normal.

- After the compressors have been operating for a few minutes (in summer operation), check that the condensing temperature measured at the pressure gauge is approximately 5 °C higher than the condenser outlet water. Check that the evaporation temperature measured at the pressure gauge is approximately 5 °C lower than the temperature of the evaporator outlet water.
- Check that the superheating of the cooling fluid is between 5 and 7 °C. To make this check, take the temperature readings indicated by a contact thermometer positioned on the compressor intake tube and on the scale of the pressure gauge also connected to intake circuit (saturation temperature corresponding to the intake pressure); the difference indicates the superheating value.
- Check that the subcooling of the cooling fluid is between 5 and 7 °C. To make this check, take the temperature readings indicated by a contact thermometer positioned on the condenser outlet tube and on the scale of the pressure gauge at the condenser liquid outlet (saturation temperature corresponding to condenser output pressure); the difference indicates the subcooling value.

TABLE III - COOLANT CHARGE - FREON R22

MODEL		21	31	36	41	61	81	91	101	141	161
MU	kg	0.5	0.6	0.7	0.8	0.9	1.0	1.4	1.6	2.0	2.3
MU/HP	kg	0.9	1.0	1.1	1.3	1.4	1.5	2.0	2.2	2.7	3.0

4.5. System shutdown

To shutdown the system, press one of the following buttons on the microprocessor for 5 seconds:



if the unit is operating in summer operation



if the unit is operating in winter operation

Important: do not shut down the unit from the main switch; this will cut off power to the guard heaters and risk damaging the compressor when restarted.

4.6. Defrosting (MU/LC/HP units only)

During winter operation (heat pump), the finned coil of the remote heat exchanger acts as an evaporator that cools and dehumidifies external air. Depending on the thermohygrometric conditions of the air, condensate or frost will form. Frost on the coil will obstruct air flow, reduce the exchange surface available and therefore the heating capacity, with the risk of permanent damage of the exchanger. All LC heat pumps are fitted with a controller that automatically defrosts the coil whenever required. The controller comprises a temperature probe in the finned coil (or pressure probe, fitted if the fan regulator low ambient kit is requested as an accessory). When the temperature (or Pressure) detected by the probe is equal to or below the calibration setting, defrosting is consented, on the condition that a minimum interval (controller setting: 30 minutes) has elapsed since the last defrost.

At this stage the following take place:

- the fans shut down;
- the 4way reversing valve is energised, reversing the cycle; the finned coil will then act as a condenser. The heat generated by condensation will melt the frost. When the condensation pressure reaches the end defrost set-point of the pressure switch, the reversing valve is again energised to restore winter operation. The defrosting cycle lasts from one to a maximum of three minutes, after which time it is stopped, even if the end defrosting set-point value has not been reached.

MU (ST) (PF) 21-36

REFRIGERANT CIRCUIT DIAGRAM CHILLER VERSION

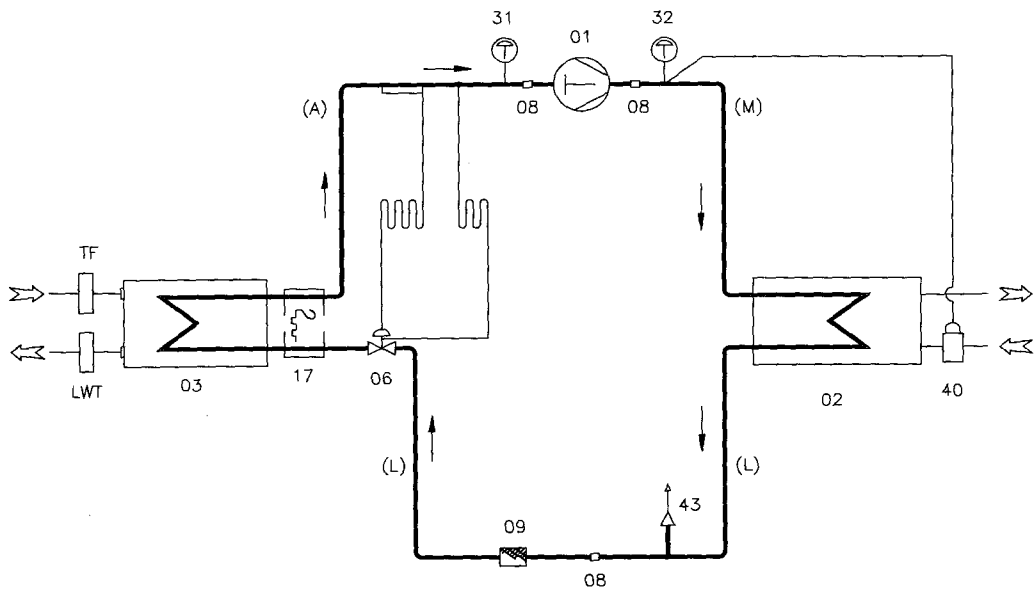

POS.	DESIGNATION	POS.	DESIGNATION
TF	TF Probe	09	Freon filter
LWT	LWT Probe	08	Charging connection
43	Melting fuse	06	Expansion valve
40	Pressostatic valve	03	Evaporator
32	High pressure switch	02	Water condenser
31	Low pressure switch	01	Hermetic compressor
17	Electric heater (optional)		

MU (ST) (PF) 41-161

REFRIGERANT CIRCUIT DIAGRAM CHILLER VERSION

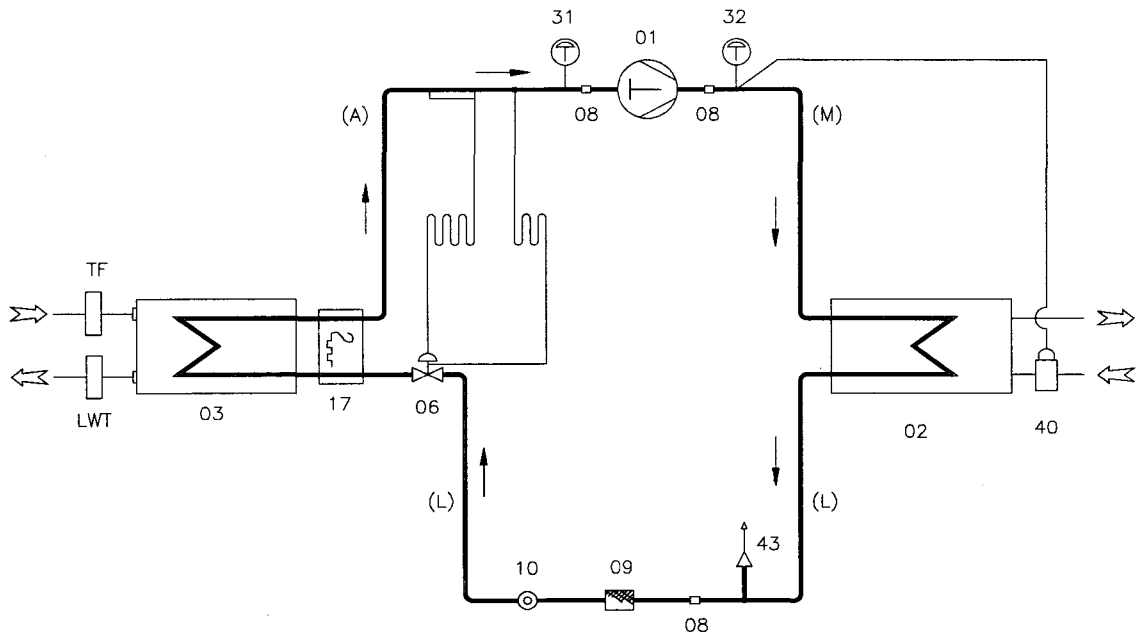

POS.	DESIGNATION	POS.	DESIGNATION
TF	TF Probe	10	Moisture indicator sight glass
LWT	LWT Probe	09	Freon filter
43	Melting fuse	08	Charging connection
40	Pressostatic valve	06	Expansion valve
32	High pressure switch	03	Evaporator
31	Low pressure switch	02	Water condenser
17	Electric heater (optional)	01	Hermetic compressor

MU (ST) (PF) HP 21-161

REFRIGERANT CIRCUIT DIAGRAM CHILLER VERSION

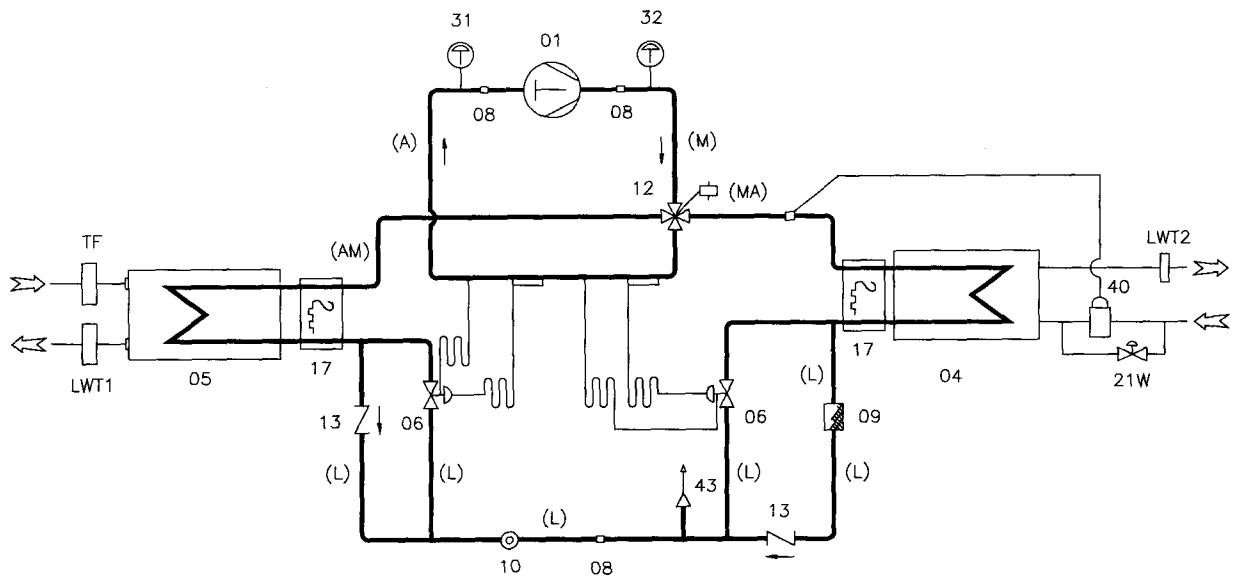

POS.	DESIGNATION	POS.	DESIGNATION
TF	TF Probe	13	Check valve
LWT1	LWT1 Probe	12	Reversing cycle valve
LWT2	LWT2 Probe	10	Moisture indicator sight glass
43	Melting fuse	09	Freon filter
40	Pressostatic valve	08	Charging connection
32	High pressure switch	06	Expansion valve
31	Low pressure switch	05	Evaporator/Condenser
21W	Solenoid valve on side loss water	04	Condenser/Evaporator
17	Electric heater (optional)	01	Hermetic compressor

MU LC (ST) (PF) 21-161

REFRIGERANT CIRCUIT DIAGRAM CHILLER VERSION

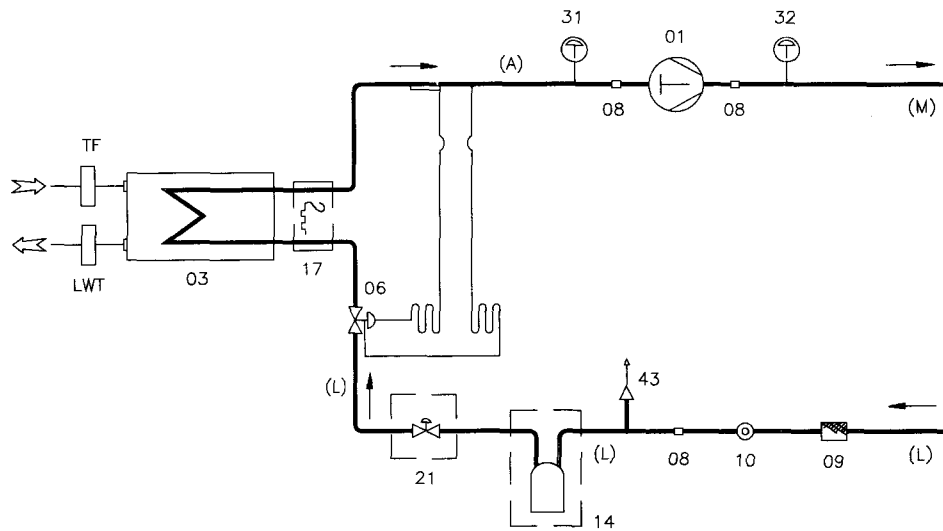

POS.	DESIGNATION	POS.	DESIGNATION
TF	TF Probe	14	Liquid receiver (optional)
LWT	LWT Probe	10	Moisture indicator sight glass
43	Melting fuse	09	Freon filter
32	High pressure switch	08	Charging connection
31	Low pressure switch	06	Expansion valve
21	Solenoid valve (optional)	03	Evaporator
17	Electric heater (optional)	01	Hermetic compressor

MU LC (ST) (PF) HP 21-161

REFRIGERANT CIRCUIT DIAGRAM CHILLER VERSION

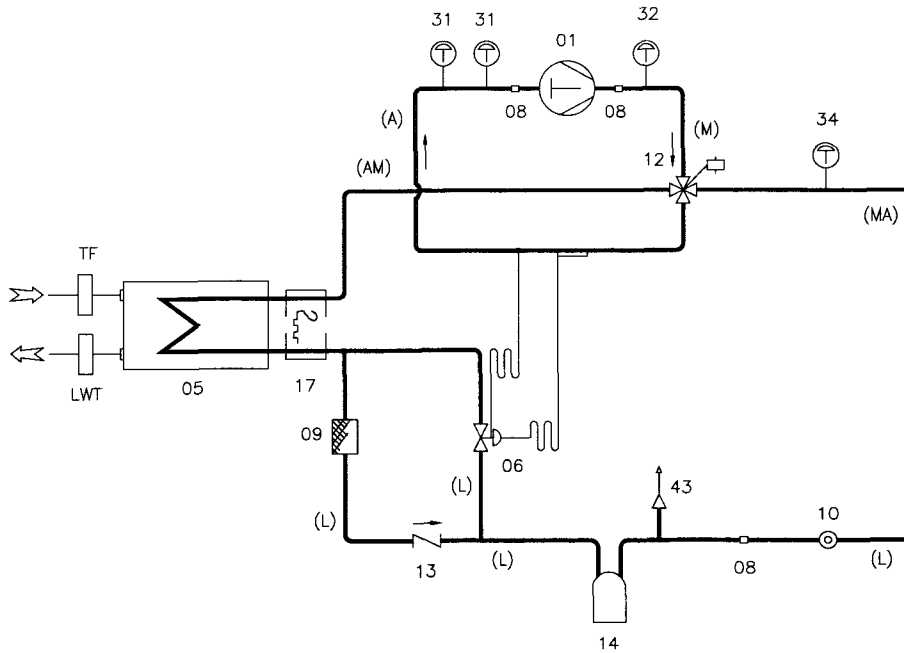

POS.	DESIGNATION	POS.	DESIGNATION
TF	TF Probe	14	Liquid receiver (optional)
LWT	LWT Probe	10	Moisture indicator sight glass
43	Melting fuse	09	Freon filter
32	High pressure switch	08	Charging connection
31	Low pressure switch	06	Expansion valve
21	Solenoid valve (optional)	03	Evaporator
17	Electric heater (optional)	01	Hermetic compressor

5. CONTROL AND SAFETY DEVICE CALIBRATION

5.1. General

All control and safety devices are factory calibrated and tested before unit delivery, though should be checked after a reasonable period of time. The calibration settings are given in **Table III**.

Servicing operations should be carried out by QUALIFIED PERSONNEL ONLY. Incorrect settings can damage the unit and be the cause of injury.

TABLE III - CONTROL AND SAFETY DEVICE CALIBRATION SETTINGS

CONTROL DEVICE		START-UP	DIFFERENTIAL	RESTART
Service thermostat (summer)	°C	12	2	automatic
Service thermostat (winter)	°C	45	2	automatic
Thermostat antifrost/antifrost 2	°C	4	4	automatic
Maximum pressure switch	bar	26	7.7	manual
Minimum pressure switch	bar	3.2	0.7	automatic
Min. pressure switch HP-winter**	bar	0.7	1	automatic
Defrosting thermostat*	bar/°C	3.2/-5	---	automatic
End defrost pressure switch *	bar	19	5	automatic
Evaporator heater thermostat	°C	4	4	automatic

* For MU/LC/HP units only

** Enabled on MU/LC/HP units during winter operation

5.2. Maximum pressure switch

The maximum pressure switch shuts down compressor operation when the delivery pressure exceeds the calibration setting.

To check the switch, cut off the air flow in the condensers (while compressors are operating); observe the compressor delivery pressure gauge (previously fitted). Check that the pressure switch cuts in (by shutting down the compressors) at the calibration setting.

Caution: in the event that the safety device does not cut in, switch off the compressor immediately.

Check that the fitted pressure gauges are efficient.

Resetting is manual, and is only possible when pressure has dropped below the differential setting (see **Table III**).

5.3. Minimum pressure switch

The minimum pressure switch shuts down the compressor when the intake pressure drops below the calibration setting.

To check its efficiency, start up a compressor; after approximately 5 minutes, close the corresponding liquid line; observe the compressor intake pressure gauge (previously fitted). Check that the pressure switch cuts in (by shutting down the compressors) at the calibration setting.

Caution: in the event that the safety device does not cut in, switch off the compressor immediately.

Check that the fitted pressure gauges are efficient.

Resetting is automatic, and is only possible when pressure has risen above the differential setting (see **Table III**).

All units are fitted with a minimum pressure switch calibrated (see **Table III**) to protect the evaporator.

Do not alter the minimum pressure switch setting without prior authorisation; incorrect settings can lead to damage to the unit.

LC heat pump units are fitted with a second pressure switch with fixed setting, enabled when the machine is operating in winter mode.

5.4. Service thermostat

The service thermostat enables and disables compressor operation (depending on chilled water requirements) according to the measurements made by a probe positioned at the user exchanger inlet. This device is microprocessor controlled.

To test thermostat efficiency, check with a thermometer on the inlet trap to the user exchanger that the temperature corresponds to the value displayed by the microprocessor. Check that the entire assembly shuts down when the calibration setting is reached (see **Table III**), e.g. with a set-point of 12 °C and a differential of 2 °C, the compressor should shut down at 12 °C and restart at 14 °C.

5.5. Antifrost thermostat

The antifrost thermostat at the user exchanger outlet (and source in HP units) has two functions: it prevents the formation of ice in the exchanger caused by an excessive drop in water flow, and it shuts down the unit in the event of service thermostat failure.

This device is microprocessor controlled.

To test its efficiency, check with a thermometer the user exchanger outlet water temperature; raise the thermostat cut-in point momentarily by slowly bringing it to the value indicated by the thermometer, at which stage the system should shut down. Return the thermostat to the calibration setting specified in **Table III**.

5.6. Flow switch

The flow switch shuts down the unit in the event of insufficient water flow to the user exchanger (or to the disposal exchanger in HP units) to prevent damage to the exchanger.

To test its efficiency, shut off the water flow to the exchanger, which should shut down. Restore the water flow; the flow switch should now allow the exchanger to operate.

5.7. Anti-recycle timer

The anti-recycle timer prevents over-frequent compressor stops and starts caused by surging of an organ in the hydraulic circuit. This device is microprocessor controlled.

The timer enables compressor start-up only after a minimum time interval (approx. 3 minutes).

Do not modify the factory delay setting: incorrect values could cause permanent damage to the unit.

5.8. Defrosting thermostat (LC heat pumps only)

The defrosting thermostat indicates when a defrosting operation is required. This device is microprocessor controlled.

To test its efficiency, check that when the saturation temperature of evaporation (read by the temperature probe in the coil or by the pressure probe) has reached the set-point value for a duration greater than 10 seconds, defrosting commences within 30 minutes.

5.9. End defrosting pressure switch (LC heat pumps only)

The end defrosting pressure switch shuts down defrosting. This device is microprocessor controlled in units fitted with optional speed control.

To test its efficiency, check that defrosting is stopped when the condensation pressure reaches the calibration setting; in this case, the 4-way reversing valve should energise and restore the heating cycle (heat pump).

6. MAINTENANCE AND PERIODIC CHECKS

6.0. Warnings

Make sure that the electricity supply to the unit has been switched off before carrying out operations or opening.

The compressor delivery pipes are heated to high temperatures; beware when operating in their vicinity.

Always close and secure unit panels after maintenance operations.

The operations described in this section MUST BE PERFORMED BY QUALIFIED PERSONS ONLY.

6.1. General

Periodic checks of unit operation are recommended:

- Check the efficiency of all control and safety devices described above (monthly).
- Check that electrical terminals in the electrical panel and the compressor terminal blocks are correctly inserted. Periodically clean moving and fixed contacts of the contactors; replace as necessary (monthly).
- Check the coolant charge shown by the liquid indicator (monthly).
- Check the compressor for oil leaks (monthly).
- Check the hydraulic circuit for water leakage (monthly).
- Prior to prolonged periods of disuse, bleed water from unit pipes and heat exchangers. This operation is necessary if ambient temperatures lower than the fluid freezing point are expected (seasonal).
- Check that water circuit is regularly replenished. (monthly).
- Check the efficiency of the flow switch (monthly)
- Check the efficiency of the compressor guard heaters (monthly).
- Clean the metal filters on the hydraulic pipes (monthly).
- Check for moisture on the liquid indicator (green = dry, yellow = moisture); if the indicator shows yellow, replace the filter (every 4 months).
- Check that the machine does not make unusual noises during operation (every 4 months).

6.2. Refrigerant circuit repairs

In the event that the refrigerant circuit has been subject to repair, the following operations are necessary:

- tightness test;
- drainage and drying of refrigerant circuit;
- coolant charging.

Drain and collect the coolant with appropriate equipment.

6.2.1. Tightness test

Charge the circuit with anhydrous nitrogen to a pressure of 15 bar. Check for leaks with a leak detector (bubbles or foam indicate the presence of leaks).

If leaks are detected, discharge the circuit completely, then repair with appropriate alloy welding.

Do not use oxygen instead of nitrogen (danger of explosion).

6.2.2. High vacuum and drying of the refrigerant circuit

To achieve high vacuum in the refrigerant circuit, use a high-power vacuum pump able to reach 0.1 mbar of absolute pressure with a rate of 10 m³/h. A single operation with this type of pump is sufficient to reach an absolute pressure of 0.1 mbar.

If a pump of the above type is not available or if the circuit has remained open for long periods of time, a "triple evacuation" procedure is recommended. This method is also advised in the event of humidity in the circuit.

Connect the vacuum pump to the charge inlets.
Proceed as follows:

- Evacuate the circuit to a pressure of at least 35 absolute mbar; charge the circuit with the nitrogen to a relative pressure of approximately 1 bar.
- Repeat the operation described above.
- Repeat the operation a third time to reach the highest pressure value possible.

This procedure is efficient for the removal of up to 99% of pollutants.

6.2.3. Coolant charge

- Connect the coolant gas bottle to the male SAE charge inlets on the unit liquid line (release some gas from the connection tube to eliminate residual air).
- Overturn the bottle and charge (in liquid form) until 75% has been loaded.
- Connect the bottle to the charge inlets on the intake line; holding the bottle upright, complete the charge until no more bubbles can be seen on the liquid indicator and the operation values specified in paragraph 4.4 have been reached.

6.2.4. Environmental considerations

Laws relating to the use of substances with a detrimental effect on the ozone layer of the atmosphere prohibit the disposal of refrigerant gases in the environment, and obliges users to collect and deliver them to the relative retail outlet or authorised disposal agency.

Coolant R22 is liable to special treatment, and must be handled in compliance with the above law.

Special attention must be paid to reduce leakage of the coolant during maintenance operations.

7. TAKING THE UNIT OUT OF SERVICE

When the unit has reached the end of its operative life and must be removed and replaced, proceed as follows:

- have the coolant gas recovered by specialised personnel and delivered to a waste disposal agency;
- recover the lubricant oil and hand over to a specialised agency for disposal;
- scrap and separate unit structure and components (if not recyclable) into material type. This applies in particular to copper and aluminium parts making up a large part of the machine structure.

The above procedures will facilitate the work of waste disposal and recycling centres, and will minimise environmental impact.

8. TROUBLESHOOTING

The following pages give a list of the most common causes for cooling system faults or breakdown. Classification is made on the basis of the most easily identified problems. Pay special attention when implementing suggested remedies: once the fault has been identified, consult the manufacturer or seek the assistance of qualified technicians.

PROBLEM	OPERATING MODE		PROBABLE CAUSE	REMEDY
	COOLING	HEATING		
A) <i>Unit does not start up</i>	⊗	⊗	Faulty connection or contacts are open	Check voltage and close contacts
	⊗	⊗	No external permissive	Check operating efficiency of water pumps and flow switches; bleed the system; check all other external permissives
	⊗	⊗	Anti recycle timer activated	Wait 5 minutes
	⊗	⊗	No permissive from service thermostat	System at operating temperature, no request; check system settings and operation
	⊗	⊗	No permissive from antifrost thermostat	Check settings and operation
	⊗	⊗	No permissive from water flow switch	Insufficient water flow. Check circulation pumps and gate valves
	⊗	⊗	No permissive from safety device	See points D-E
	⊗	⊗	Compressor is faulty	See point B

PROBLEM	OPERATING MODE		PROBABLE CAUSE	REMEDY
	COOLING	HEATING		
B) <i>Compressor does not start up</i>	⊗	⊗	Compressor is burned out or has seized	Replace.
	⊗	⊗	Compressor contactor de-energised	Check voltage at compressor coil and coil continuity
	⊗	⊗	<i>Power circuit open</i>	Locate triggered safety device; close compressor circuit
C) Compressor repeatedly starts and stops	⊗	⊗	Compressor contactor faulty	Check and replace as necessary
	⊗	⊗	Compressor is faulty	Check and replace as necessary - See point B

PROBLEM	OPERATING MODE		PROBABLE CAUSE	REMEDY
	COOLING	HEATING		
D) Compressor does not start up due to maximum pressure switch	⊗	⊗	Pressure switch is faulty	Check and replace as necessary
	⊗	⊗	Coolant charge excessive	Discharge excess gas
	⊗		Source exchanger (condenser) metal filter is clogged. Insufficient water flow	Clean filter
		⊗	User exchanger (condenser) metal filter is clogged. Insufficient water flow	Clean filter
	⊗		Source exchanger (condenser) water circulation pump is faulty	Check pump; replace as necessary
		⊗	User exchanger (condenser) water circulation pump is faulty	Check pump; replace as necessary
	⊗	⊗	Non condensable gas present in refrigerant circuit	Discharge then recharge the circuit - See paragraph 6.2
LC UNIT	⊗		Condensing coil is clogged, insufficient air flow	Clean coil with pressurised air
	⊗		Condenser fan is faulty	See point P
	⊗		Condenser (CRCF) fans turn in opposite direction	Invert direction of rotation
		⊗	End defrosting pressure switch is faulty	Check and replace switch as necessary

PROBLEM	OPERATING MODE		PROBABLE CAUSE	REMEDY
	COOLING	HEATING		
E) Compressor does not start up due to intervention of minimum pressure switch	⊗	⊗	Pressure switch faulty	Check and replace as necessary
	⊗	⊗	Machine is completely discharged	See point F
	⊗		User exchanger (evaporator) metal filter is clogged. Insufficient water flow	Clean filter
		⊗	Source exchanger (evaporator) metal filter is clogged. Insufficient water flow	Clean filter
	⊗		User exchanger (evaporator) water circulation pump is faulty	Check pump; replace as necessary
		⊗	Source exchanger (evaporator) water circulation pump is faulty	Check pump; replace as necessary
	⊗	⊗	Coolant filter clogged	Check and replace as necessary
	⊗	⊗	Thermostatic expansion valve fault	Check, clean or replace valve as necessary
LC UNIT		⊗	Evaporator coil is clogged; insufficient air flow	Clean coil with pressurised air
		⊗	Ice on evaporator coil	See point H
		⊗	Evaporator fans are faulty	See point M
	⊗		Condenser (CRCF) fans turn in opposite direction	Invert direction of rotation

PROBLEM	OPERATING MODE		PROBABLE CAUSE	REMEDY
	COOLING	HEATING		
F) No gas	⊗	⊗	Leak in refrigerant circuit	Pressurise circuit to approx. 4 bar and check with leak detector. Repair leak, then recharge circuit; see paragraph 6.2
G) Liquid pipe is hot	⊗	⊗	Insufficient coolant charge	See point F
H) Unit works continuously	⊗	⊗	No coolant gas	See point F
	⊗	⊗	Operating thermostat incorrectly calibrated or faulty	Check thermostat calibration; replace microprocessor board as necessary
	⊗	⊗	Thermal load excessive	Reduce thermal load
	⊗	⊗	Compressor does not have expected cooling capacity	Check and replace as necessary
	⊗	⊗	Liquid filter is clogged	Clean and replace as necessary

PROBLEM	OPERATING MODE		PROBABLE CAUSE	REMEDY
	COOLING	HEATING		
I) Liquid pipe is frozen	⊗		Liquid filter is clogged	Replace filter cartridge
L) Unit operates regularly but with insufficient capacity	⊗	⊗	Insufficient coolant charge	See point F
	⊗	⊗	Presence of humidity in cooling circuit	Dry or replace the filter as necessary
M) Unit operates in incorrect mode		⊗	Four-way reversing valve is de-energised	Check power supply and valve coil; replace valve as necessary
N) Compressor intake pipe is frozen	⊗	⊗	Thermostatic expansion valve is faulty	Check, clean and replace as necessary
	⊗		Water circulation pump is fault	Check pump; replace as necessary
	⊗	⊗	Insufficient coolant charge	See point F
	⊗	⊗	Liquid filter is clogged	Clean or replace as necessary
MU LC UNITS O) Defrost cycle does not start up		⊗	Defrosting thermostat is faulty or incorrectly calibrated	Check thermostat calibration; replace microprocessor board as necessary
		⊗	Four-way reversing valve is de-energised	Check power supply and valve coil; replace valve as necessary
		⊗	Defrosting probe not in contact with coil	Position probe correctly

PROBLEM	OPERATING MODE		PROBABLE CAUSE	REMEDY
	COOLING	HEATING		
MU LC UNITS P) Fan does not start up	⊗	⊗	Fan belt loose or broken (CRCF unit)	Tighten or replace belt as necessary
	⊗	⊗	Fan motor contact is de-energised (CRCF unit)	Check voltage at contactor coil ends and coil continuity
	⊗	⊗	Fan thermal relay has cut in (CRCF unit)	Check insulation between windings, and between windings and mass. Reduce belt tension.
P) (Continued)	⊗	⊗	Speed control incorrectly calibrated or faulty (CRAX unit)	Check control calibration or replace as necessary
	⊗	⊗	Fan motor is faulty	Check motor; replace as necessary
Q) System unusually noisy	⊗	⊗	Pipes vibrate	Secure pipes with brackets
	⊗	⊗	Compressor is noisy	Check compressor; replace as necessary
	⊗	⊗	Thermostatic valve is noisy	Check valve; add coolant as necessary
	⊗	⊗	Unit panels vibrate	Secure panels
R) Pump does not start up ST UNIT	⊗	⊗	Pump blocked following long period of disuse	Free the pump rotor
	⊗	⊗	Pump has burned out	Check pump; replace as necessary
	⊗	⊗	Insufficient water in circuit	Check circuit for leaks; replenish circuit water

10. DIMENSIONS AND WEIGHTS

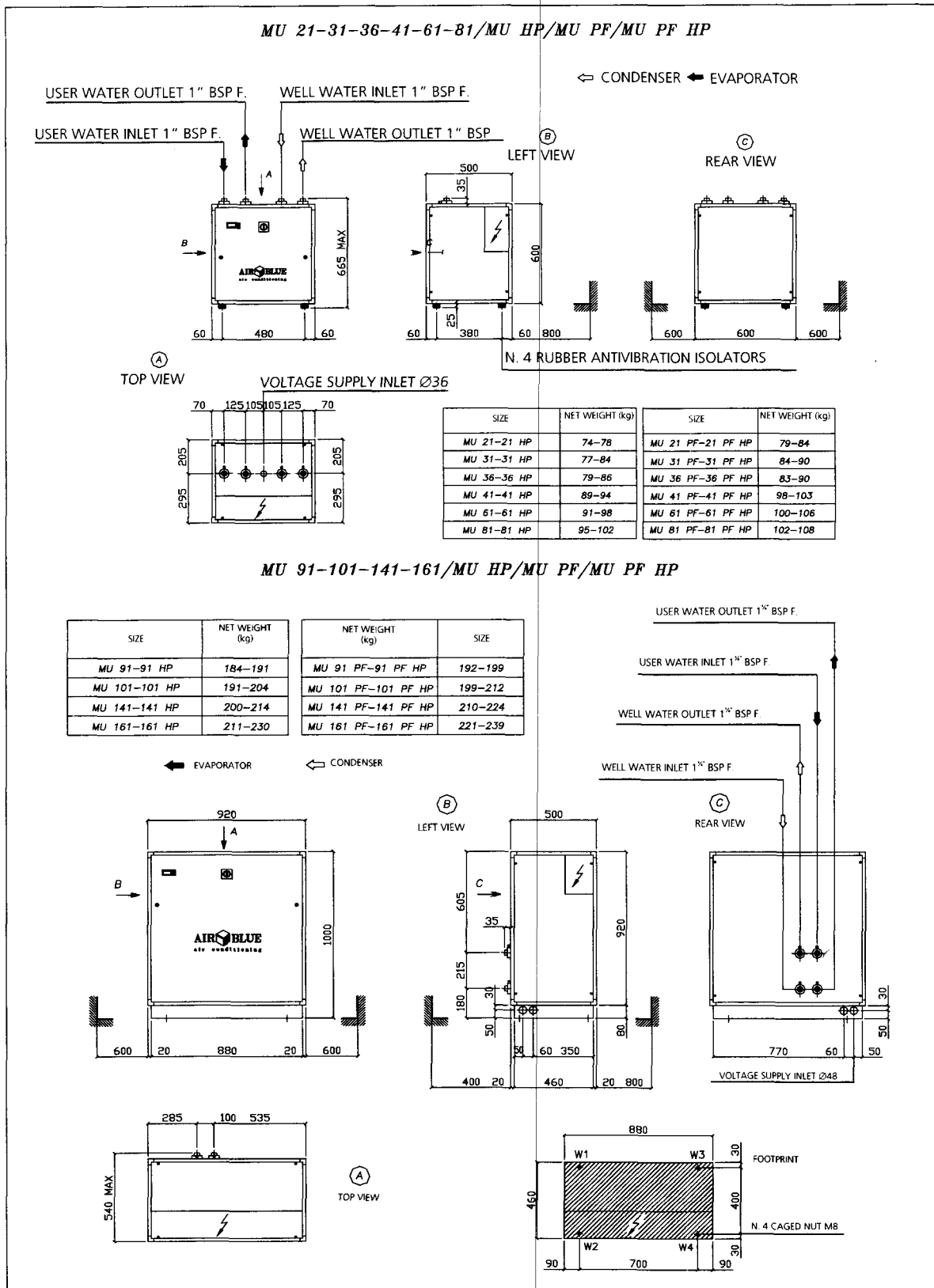

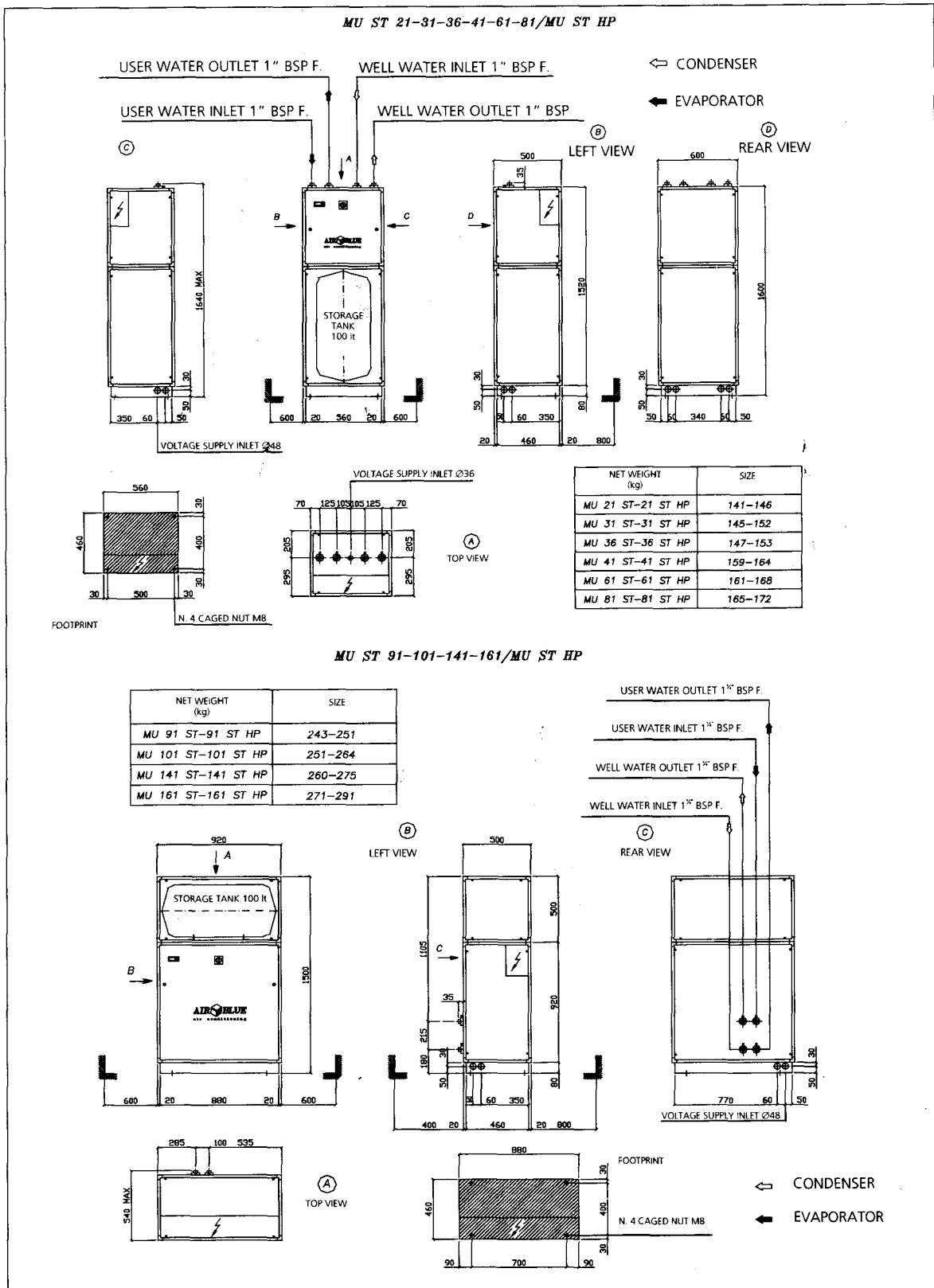

MU LC 21-31-36-41-61-81/MU LC HP/MU PF LC/MU PF LC HP

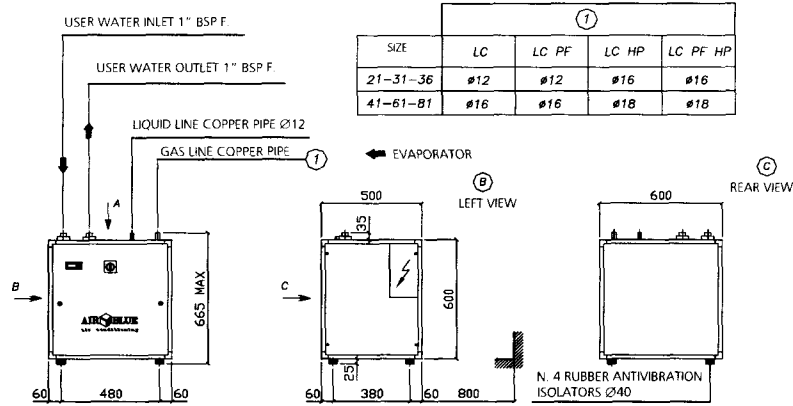

SIZE	NET WEIGHT (kg)	SIZE	NET WEIGHT (kg)
MU 21 LC-21 LC HP	68-72	MU 21 PF LC-21 PF LC HP	73-77
MU 31 LC-31 LC HP	74-78	MU 31 PF LC-31 PF LC HP	77-81
MU 36 LC-36 LC HP	75-79	MU 36 PF LC-36 PF LC HP	78-82
MU 41 LC-41 LC HP	81-86	MU 41 PF LC-41 PF LC HP	90-94
MU 61 LC-61 LC HP	85-89	MU 61 PF LC-61 PF LC HP	92-96
MU 81 LC-81 LC HP	88-92	MU 81 PF LC-81 PF LC HP	95-99

MU LC 91-101-141-161/MU LC HP/MU PF LC/MU PF LC HP

